

SPECIFICATIONS

10 INCH SELF PRIMING

Premier Pump Model P3WSP8A-4045TF285-120 Engine Driven, Heavy Duty Solids Handling Pump

Pump Specifications:

- Pump size: 10"X 10" flange to flange
- Pump Casing: Ductile Iron
- Operating pressure: Maximum 120 psi (797 kPa)
- Impeller: Open type, two vane, cast steel. Passes 3" solids
- Impeller Shaft: Stainless steel No. 17-4PH
- Wear Plate: Replaceable, Hardened Carbon Steel no. 1015
- Cover Plate: Removable/adjustable ductile iron 30
- Flap valve: Neoprene with steel reinforcing ring
- Bearing housing: Ductile Iron
- Seal Plate: Ductile Iron
- Shaft Sleeve: 17-4PH stainless steel
- Radial Bearing: Open single ball
- Thrust Bearing: Open double ball
- Bearing/Seal Cavity Lubrication: SAE No. 30 oil
- Flanges: 125# Ductile iron ANSI
- Gaskets: Buna-N, compressed synthetic fibers, vegetable fiber, PTFE, cork, and rubber
- O-Rings: Buna-N
- Hardware: Plated steel/grade 8/SST
- Pressure release valve: Brass

Optional Equipment and Materials: Hi-Chrome, CD4MCu. Automatic air release valve, 120V/240V casing heater. High pump temperature shutdown kit, moisture probe, gauge kit, Other elastomers available.

Engine Specification:

- Model: John Deere model 6068TF285
- 115 intermittent horsepower @ 2400 RPM
- Six cylinder, four cycle, water cooled diesel engine
- Governor: Mechanical
- Lubrication: Force Feed
- Air Cleaner: Filter element
- Fuel Tank: 120 US gallons
- Run time: Full load (1800 RPM) ~ 24 hours
- Starter: 12 volt electric

Standard features: Safety shutdown switches for low oil pressure and high temperature. Instrument panel with temperature and oil pressure gauge, ampmeter, hourmeter and tachometer. Muffler with rain cap. Engine to pump coupling: SAE4 housing with 10" rubber disc drive.



Pictured: P3WSP6A-4045TF280-T60

Standard Skid: Heavy duty fabricated steel frame. Integral fuel tank, lifting bilt, lockable fuel tank, and one 1½" clean-out/drain plug

Standard Trailer: Heavy duty fabricated steel frame, integral fuel tank, fenders, lifting bail, lockable fuel cap, Dual 5200# Anti-torsional axles, two (2) front adjustable leveling jacks and two (2) rear adjustable leveling jacks, one 1½" clean-out plug, fuel gauge, adjustable height tongue with easy conversion from ball hitch to Lunette eye

Trailer Options: DOT light package, work lights, special tires & wheels, dual axles, diamond plate fenders, surge brakes, lockable enclosed instrument panel, lockable enclosed engine housing, storage box, hose rack and more

Specifications subject to change without notice

Premier Pump and Power, LLC • PO Box 6423 • Vancouver, WA 98668 • Phone 360.574.4519 • Fax 772.679.5989



PREMIER PUMP & POWER
THE WAVE OF THE FUTURE

Premier Pump and Power, LLC

www.wastewaterpumps.net

PREMIER PUMP AND POWER, LLC Self Primer Series

PO Box 6423
Vancouver, WA 98668
Phone 360.574.4519
Fax 772.679.5989
www.wastewaterpumps.net

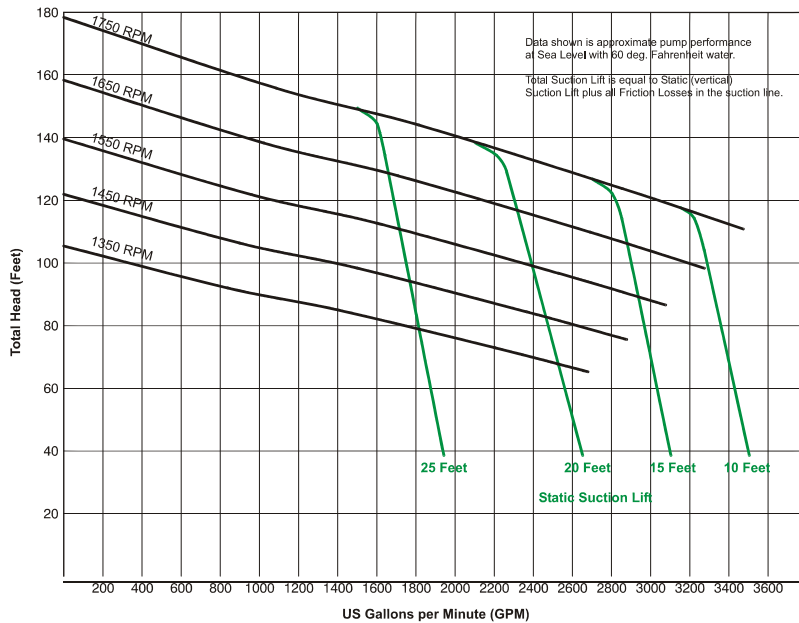

Suction: 10"
Discharge: 10"
Impeller Diameter: 13.25"
Max. Solid Sphere: 3.00"

Determine NPSHR prior to using repriming table. Do not use available suction lifts

Clear Water Performance

$$BHP = \frac{GPM \times FT \times SG}{3960 \times Efficiency}$$

$$KW = \frac{M^3 / HR \times M \times SG}{367 \times Efficiency}$$

Certified tests are performed using Hydraulic Institute acceptable level II.

MAY 2008

RPM
Variable

P3WSP10A

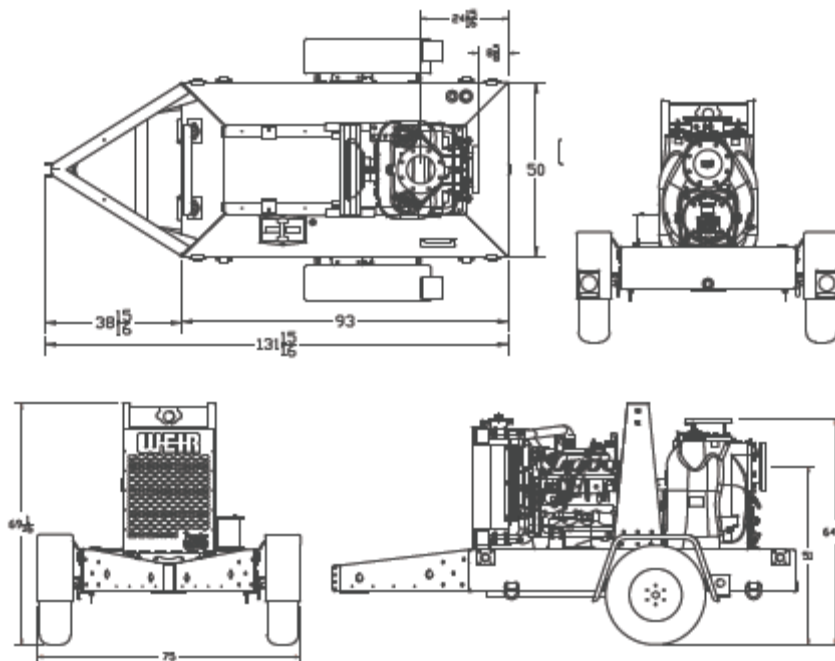

Specifications subject to change without notice

Premier Pump and Power, LLC • PO Box 6423 • Vancouver, WA 98668 • Phone 360.574.4519 • Fax 772.679.5989