

SPECIFICATIONS

4 INCH DRY PRIME

Premier Pump Model 4x4CS2L-VP-3TNV88-52

Vacuum Assisted, Engine Driven, Heavy Duty Solids Handling Pump

Pump Specifications:

- Pump size: 4"X 4" AISI 150# flanges standard
- Suction Cover: ASTM A48 class 30 gray iron
- Wear Ring: ASTM A48 class 30 gray iron
- Volute Casing: ASTM A48 class 30 gray iron
- Volute Cleanout: Handhole type, ASTM A48 class 30 gray iron
- Backplate: ASTM A48 class 30 gray iron
- Bracket: ASTM A48 class 30 gray iron
- Mechanical Seal: Tungsten vs. Silicon Carbide seal faces, Viton elastomers, 300 series stainless steel hardware & spring, seal system designed for dry running
- Impeller: Enclosed type, two port, non clog, w/3 inch spherical solids handling capability. ASTM A48 class 30 gray iron
- Bearing Housing: ASTM A48 class 30 gray iron
- Pump-end Bearing: Single row ball – 6313-C3
- Drive-end Bearing: Single row ball – 6313-C3
- Shaft: 1144 Stressproof steel (Other metals available including: 17-4 PH corrosion resistant)
- Lip Seals: CR type, single lip: Bearings, SAE cover - Buna-N, Seal gland – Viton
- Midland 1300 series compressor. Lubricated by engine oil and cooled by engine water
- Separator Spool: Standard steel
- Air/Water chamber: Chamber designed to separate air and water before entering the pump case
- Venturi: Constructed of non-corrosive bronze
- Discharge check valve: Swing type, cast iron w/Buna-N disc (Viton optional)

Optional Equipment and Materials: Stainless Steel, CD4MCU & Ductile Iron

Engine Specification:

- Model: Yanmar model 3TNV88
- 36 intermittent horsepower @ 3000 RPM
- Three cylinder, four cycle, water cooled diesel engine
- Governor: Mechanical
- Lubrication: Force Feed
- Air Cleaner: Filter element
- Fuel Tank: 52 US gallons
- Run time: Full load (1800 RPM) > 24 hours
- Starter: 12 volt electric



Standard engine features: Safety shutdown switches for low oil pressure and high temperature. Instrument panel with temperature and oil pressure gauge, ampmeter, hourmeter and tachometer. Muffler with rain cap. Engine to pump coupling: SAE5 housing with 7.5" rubber disc drive.

Standard Skid: Heavy duty fabricated steel frame. Integral fuel tank, lifting bale, lockable fuel tank, and one 1½" clean-out/drain plug

Standard Trailer: Heavy duty fabricated steel frame, integral fuel tank, fenders, lifting bail, lockable fuel cap, 3500# Anti-torsional axle, two (2) front adjustable leveling jacks and two (2) rear adjustable leveling jacks, one 1½" clean-out plug, fuel gauge, adjustable height tongue with easy conversion from ball hitch to Lunette eye

Trailer Options: DOT light package, work lights, special tires & wheels, dual axles, diamond plate fenders, surge brakes, lockable enclosed instrument panel, lockable enclosed engine housing, storage box, hose rack and more

Specifications subject to change without notice

Premier Pump and Power, LLC • PO Box 6423 • Vancouver, WA 98668 • Phone 360.574.4519 • Fax 772.679.5989



PREMIER PUMP & POWER
THE WAVE OF THE FUTURE

Premier Pump and Power, LLC

www.wastewaterpumps.net

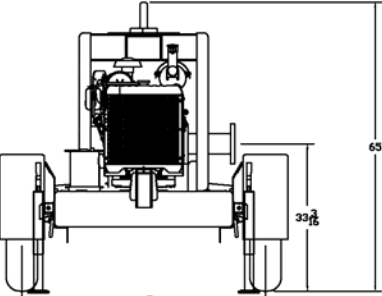
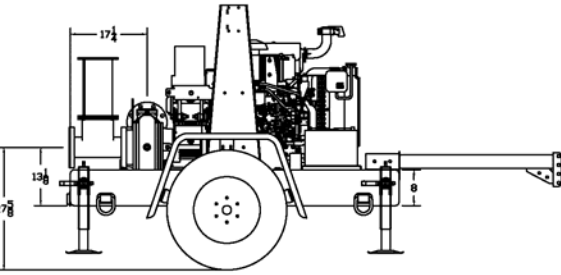
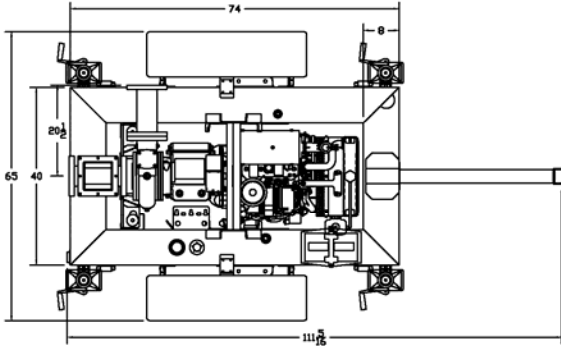
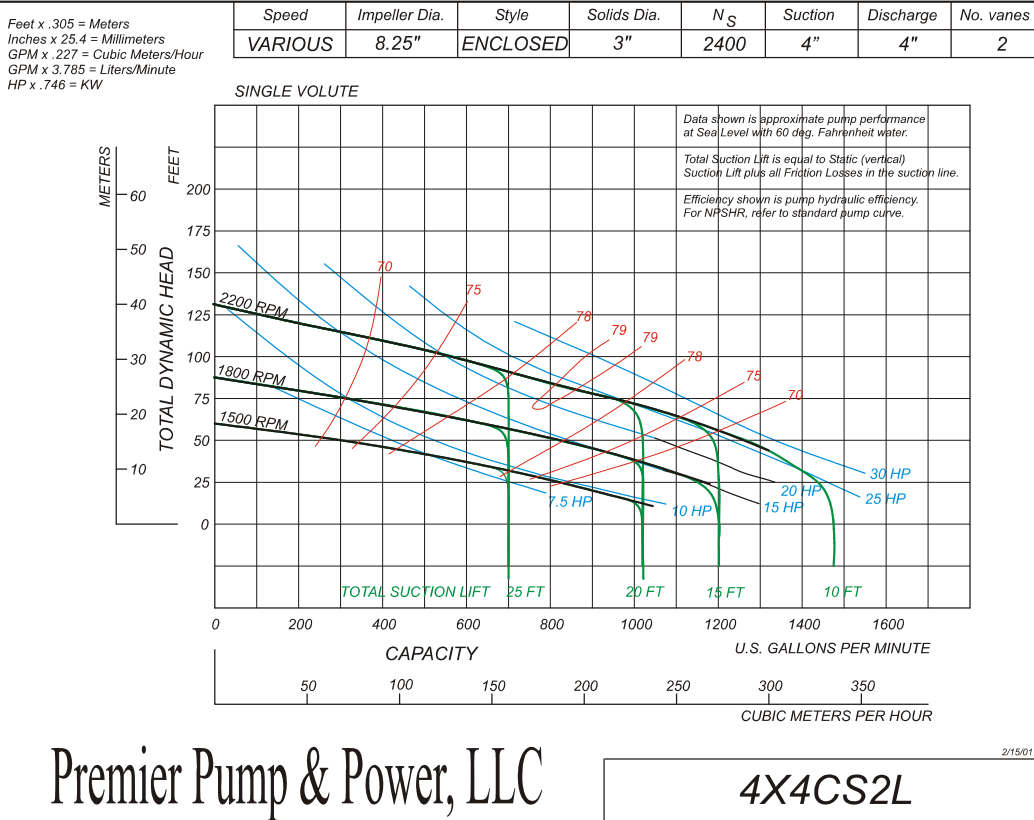

Performance Data

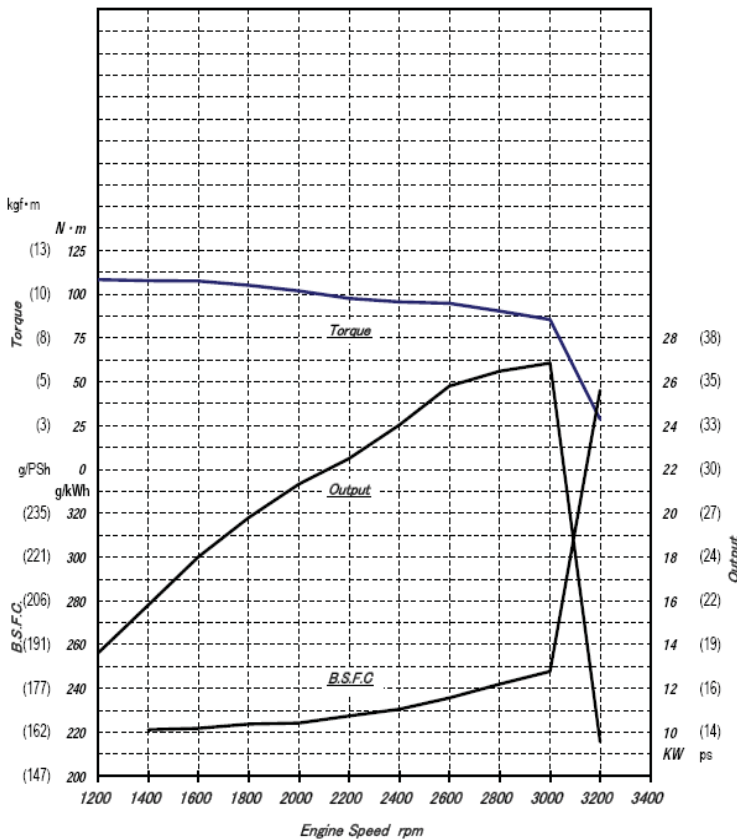

kW to Hp conversion used is expressed as: $HP = (kW \text{ value}) \times 1.34$

Rated Speed (rpm)	Net rated kW	Net rated HP	Max. Torque (ft-lb)
3000	26.9	36.0	79.5 @ 1800 rpm

Ratings Definitions and Conditions

*Rated power listed is NET engine output. The engine operating environment and driven machine conditions must be studied carefully when selecting an engine in order to ensure correct engine selection, maximize engine performance, extend engine service life and improve machine capacity.

Consult the TNV Application Manual for additional engine ratings and engine application information.

Application standards for Yanmar industrial engines: Inlet air standard conditions with a total barometric pressure of 100kPa (29.5 in. Hg), with a vapor pressure of 1 kPa (.295 in. Hg), and 25°C (77°F).

Dimensions

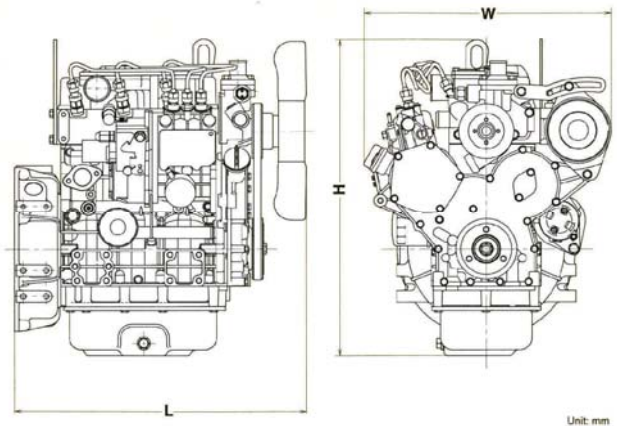

Length	24.0 in (610 mm)
Width	19.7 in (502 mm)
Height	25.7 in (654 mm)

Note: Dimensions depend on final specifications.

Materials and specifications herein are intended to serve as a guide in engine selection and subject to change without notice. The International System of Units (SI) is used in this publication. Yanmar and its logos, as well as corporate identity used herein, are trademarks of Yanmar and may not be used without permission.